

# Flame/Plasma CNC Cutting System

- Support Dynamic Pierce
- Better operation design
- Better work stability
- Input Power:  
AC24V+5%, 50Hz/60Hz
- Output Current: 1A-4A,
- Load capacity: 100W,
- Working temperature:  
-10 $\infty$ 60 $\infty$ C
- Voltage Divide ratio :100:1
- Control accuracy : $\pm 1V\infty\pm 3V$



**XPTHC-100III**  
**Arc Voltage**  
**Torch Height Controller**

# Arc Voltage Torch Height Controller XPTHC-100 Instruction Manual



**HYD CNC**

Please read this manual fully before use

---

In 2012, the new XPTHC-100III image as follow,



***New features***

.....

- Support Dynamic Pierce***
- More indicators for trouble-shooting***
- Better operation design***
- Better work stability***

---

# Table of Conetents

<b>1、Intro</b> .....	错误！未定义书签。
<b>1.1 product name and model</b> .....	- 5 -
<b>1.2 Basic parameters</b> .....	- 5 -
<b>1.3 Application</b> .....	- 5 -
<b>1.4 components</b> .....	- 5 -
<b>1.5 Basic functions</b> .....	- 6 -
<b>1.6 Work Process</b> .....	- 7 -
1.6.1 Work with IHS .....	- 7 -
1.6.2 Work without IHS .....	- 7 -
<b>2、XPTHC-100III Commissioning and Set</b> .....	- 8 -
<b>2.1 Operation panel intro</b> .....	- 8 -
<b>2.2 Voltage divider</b> .....	- 10 -
2.2.1 None-isolation voltage divide.....	- 10 -
2.2.2 Isolation voltage divide .....	- 11 -
<b>2.3 IHS</b> .....	- 11 -
2.3.1 Torch retaining cap IHS.....	- 12 -
2.3.2 Proximity switch IHS.....	- 13 -
<b>3. Connection intro</b> .....	- 15 -
<b>3.1 Power connection</b> .....	- 15 -
<b>3.2 Motor connection</b> .....	- 16 -
3.2.1 TO TORCH connector intro .....	- 16 -
3.2.2 Drive circuit intro and current set.....	- 16 -
<b>3.3 TO CNC Connection</b> .....	- 17 -
<b>3.4 Plasma connection</b> .....	- 18 -
<b>3.5 Proximity switch connection</b> .....	- 18 -

---

<b>4. Wiring</b> .....	错误！未定义书签。
<b>5.Maintenace</b> .....	<b>- 19 -</b>
<b>5.1、 Trouble shooting</b> .....	<b>- 20 -</b>
<b>5.2、 Advice</b> .....	<b>- 22 -</b>

---

# 1. Intro

## 1.1 Product name and model

Arc voltage torch height controller XPTHC-100III

## 1.2 Basic parameter

- ◆ Input Power : AC24V $\pm$ 5%, 50Hz/60Hz
- ◆ Down/Up Motor : DC24V DC MOTOR
- ◆ Motor Drive: PWM ;
- ◆ Output Current : 1A-4A, Load capacity : 100W,
- ◆ Working temperature : -10 $\sim$ 60 $^{\circ}$ C
- ◆ Voltage Divide ratio :100:1
- ◆ **Control accuracy** :  $\pm$ 1V $\sim$  $\pm$ 3V
- ◆ Size : length \*width \*height : 320mm\*260mm\*90mm
- ◆ The speed of lifting : 1000mm/min $\sim$ 4000mm/min(Contact the supplier if it exceeds the range of speed)
- ◆

## 1.3 Application

XPTHC-100III supports almost all plasma cutters on market like Hypertherm, Thermal Dynamics...include HD plasmas like HPR130, 260, Ultra-cut series....

And it supports all CNC cutting controllers on market like Hypertherm, Burny industrial level controllers or Mach3 such DIY controllers, because XPTHC-100III can start Auto Height control with or without Auto enable signal from CNC. But with Auto enable/disable signal from CNC, THC would work better.

## 1.4 Components

XPTHC-100III includes follow parts

- A、XPTHC-100III Control module,**
- B、Voltage divider,**
- C、All related connectors.**

---

## 1.5 Basic functions,

### A、 Auto Initial Height Sensing(IHS) :

**Torch Retaining Cap IHS and Proximity Switch IHS** (NPN and PNP), Proximity Switch IHS is backup for Torch Retaining Cap IHS for cutting dirty/rusty workpiece, needing the Anti-Collision Fixture(breakaway kit).

### B、 Torch Anti-Collision Function:

We designed Touch-Up circuit for Anti-Collision Function. No matter it is on Auto Control Model or Manual Control Model, when torch head touches the workpiece, THC would automatically lift torch up to IHS height. **So with XPTHC-100, even in Manual Control Model, user doesn't need to worry about torch head crashing.**

### C、 Freeze Auto Height Control on Corner Signal

XPTHC-100 can recognize Corner Signal from CNC and freeze Auto Control Model on receiving this signal, and we have a unique design to backup this function. **We set 30V (adjustable) as Turning Point according to our years practice.** When the Actual Arc Voltage is higher than Set Arc Voltage over 30V, THC Auto Control Mode freezes to avoid torch head diving, until it goes back to 30V range. This Over Voltage protection can avoid torch diving on voltage spikes (Corner Turning, Kerf Crossing) effectively.

### D、 Lifting torch Up on IHS Disabled status.

On IHS Disabled status, jogging torch head down until it reaches workpiece, when Arc Starts, torch head would lift up automatically to the Set Height set via the button SET-IHS.

### E、 Lifting Torch Up on TURN ON or Arc Off:

When CNC is TURN ON or Plasma Arc Off, THC would lift torch up for 2 seconds, **please notice this Function during commissioning, avoiding the possible damage of limit switch or lift device.**

### F. Set Pierce Delay Time.

Set Button Set-PIERE (set Pierce delay time), to delay output this signal, it is a switch signal, set to detect arc voltage lead in THC. Once THC detect arc lead in, it send arc ok signal to CNC to start cut.

---

**Dynamic Pierce works by receiving plasma's Dynamic Pierce signal ( Kjellberg plasma has this signal) or plasma's arc feedback signal. After IHS, THC controls plasma start arc, and it lifts torch up when arc strikes. It is to protect the torch tip and electrode; consumables can work longer in this way.**

#### **G. Manual Operation**

Many functions can be Manually operated on Operation Panel of XPTHC-100, such as, set Auto/Manual mode of THC, manually control torch Up and Down, IHS test, Arc Start test.....etc.

#### **H. Arc Voltage Divide**

Isolation Voltage Divide, the Voltage Divide ratio is 100:1/50:1. Once Isolation Voltage Divide function damaged, user can also use Non-isolation Voltage Divide on our voltage divider.

### **1.6 Work process**

#### **1.6.1 work with IHS,**

When CNC send out Arc Start Signal(IHS enabled), THC starts with IHS, then send Arc Start Signal to plasma, after plasma start, THC delay lead in arc voltage from plasma( set pierce delay time), THC send Arc Feedback(arc ok) Signal to CNC to start Cut after arc voltage lead in. If THC is on Auto Model, and CNC Auto Control enabled, then cutting is under THC Auto control.

#### **1.6.2 work without IHS**

When CNC send out Arc Start Signal (IHS disabled), THC starts without IHS, lifts torch to the set height (set via button SET-IHS), then send Arc Start Signal to plasma, after plasma start, THC delay lead in arc voltage from plasma ( set pierce delay time), THC send Arc Feedback(arc ok) Signal to CNC to start Cut after arc voltage lead in. If THC is on Auto Model, and CNC Auto Control enabled, then cutting is under THC Auto control.

**We don't recommend work without IHS**



## 2、XPTHC-100III commission and set

### 2.1 Operation panel intro

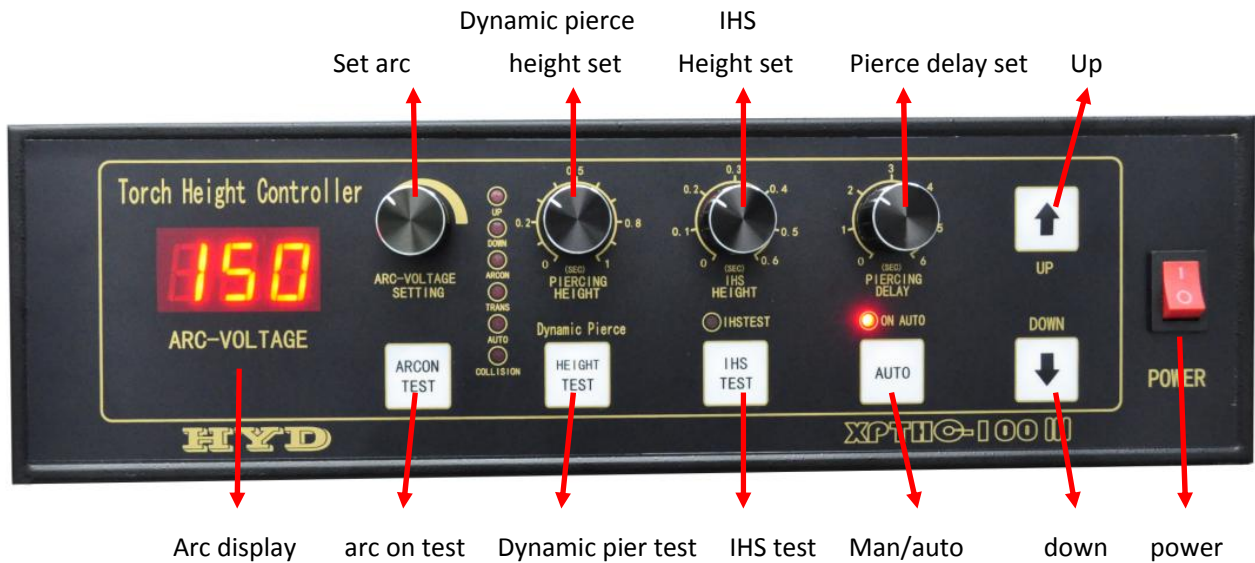

Figure 2-1 operation panel

#### Arc Voltage

Before Arc Start it shows the Set Arc Voltage, after it shows the Actual Arc Voltage.

#### ARC-VOLTAGE SETTING

Based on the thickness of steel plate being cut and cutting speed, it shall be set according to the parameter offered by Plasma, and it will be showed on operation panel. Set Arc Voltage decides the Torch Height during cut, the higher the arc is, the higher the Torch Height will be. On Auto mode, adjust the Set Voltage means adjusting the Torch Height.

#### Pierce HEIGHT

Increase on clock-wise turn, decrease on anti-clockwise. Pierce height means torch lift up height after receiving dynamic pierce signal from plasma or arc feedback signal from plasma. It is used on cutting thick material. If the dynamic pierce signal is disconnected, this function is disabled.

#### IHS HEIGHT

Set Initial Height, turn clockwise, the height increases.

#### PIERCING DELAY

---

Set the Delay Time from Plasma Start to CNC starts cut (delay lead in arc voltage into THC), the Arc feedback (arc ok) signal would be sent to CNC only after arc voltage is detected by THC.

### **IHS-test**

Press one time, it would check IHS one time, which is used to check whether it is a workable IHS or not.

### **Auto**

Set THC Auto or Manual mode. Meanwhile enables the Auto Signal between connectors of CNC and THC, (for EDGE system, the Auto Signal shall be connected as Normally Closed.)

### **ARCON TEST**

Press and hold, to test the Plasma Start. During test, Torch lifts up an IHS height.

### **Up/down**

Manual operation button of Up and Down. It is effective on any mode.

### **Indicators:**

**DOWN Indicator:** Turn on when torch lift down

**Collision Indicator:** Turn on when torch touch workpiece or proximity switch effective.

**ARCON Indicator:** Turn on when THC sends arc start signal out. If arc start with IHS enable, this indicator is off until IHS completed.

**TRANS Indicator:** Turn when THC receives arc feedback signal, and sent out Arc OK signal to CNC.

**AUTO Indicator:** On means THC is on Auto Mode, four conditions have to be completed: 1, CNC Auto Height Control (THC) enables; 2, THC is on Auto Model; 3, arc voltage has been lead in THC; 4, Actual Arc Voltage not higher than Set Arc Voltage over 30V.

### **Note**

**A、 When THC on Auto Mode, the 5 indicators all should be ON, if anyone is OFF, that means Auto Mode failed, please check the reason according to indicators.**

B、 There are 6 indicators on Operation panel, demo THC from Torch down—Touch workpiece—arc start---arc feedback---Auto on, please check the failure reason from the one by one step.

## 2.2 voltage divider

Our Voltage Divider offers two modes of Voltage Divide, None Isolation Voltage Divide is backup for Isolation Voltage Divide.

### 2.2.1 None isolation voltage divide

**Note: Plasma output positive pole is GND, negative pole connected with electrode in torch. DO NOT mis-connected, or THC will be UN-Effective.**

As None Isolation Voltage Divide is directly connected with Plasma Power Supply, to enable THC escape from interference caused by the HF during Plasma Arc Start, the Divided Arc Voltage guided into THC is Time-Delayed.

It just needs to prolong the time of lead Arc Voltage into THC, this interference can be avoid effectively.

As showed in figure 2-2

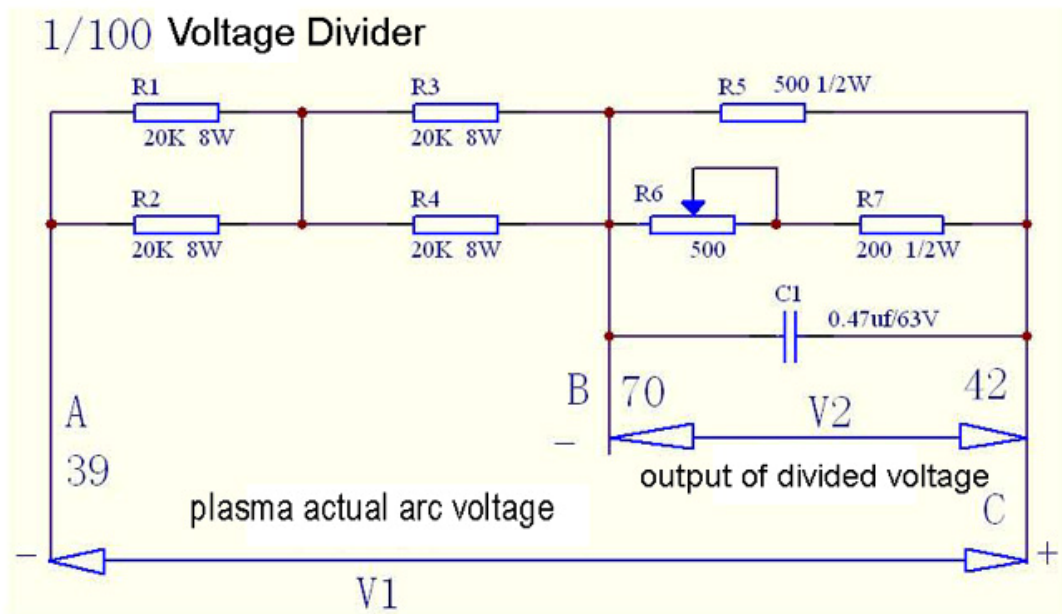

Figure 2-2

## 2.2.2 Isolation voltage divide

Plasma Arc Voltage is divided by Voltage Divider (offered with THC) on 100:1 via none isolate voltage divide, lead into THC after processed by Isolation Circuit. Arc voltage has little effect on THC after Isolation Circuit. This Voltage Divider can be connected as Isolation Voltage Divide or None Isolation Voltage Divide mode.

As showed in figure 2-3

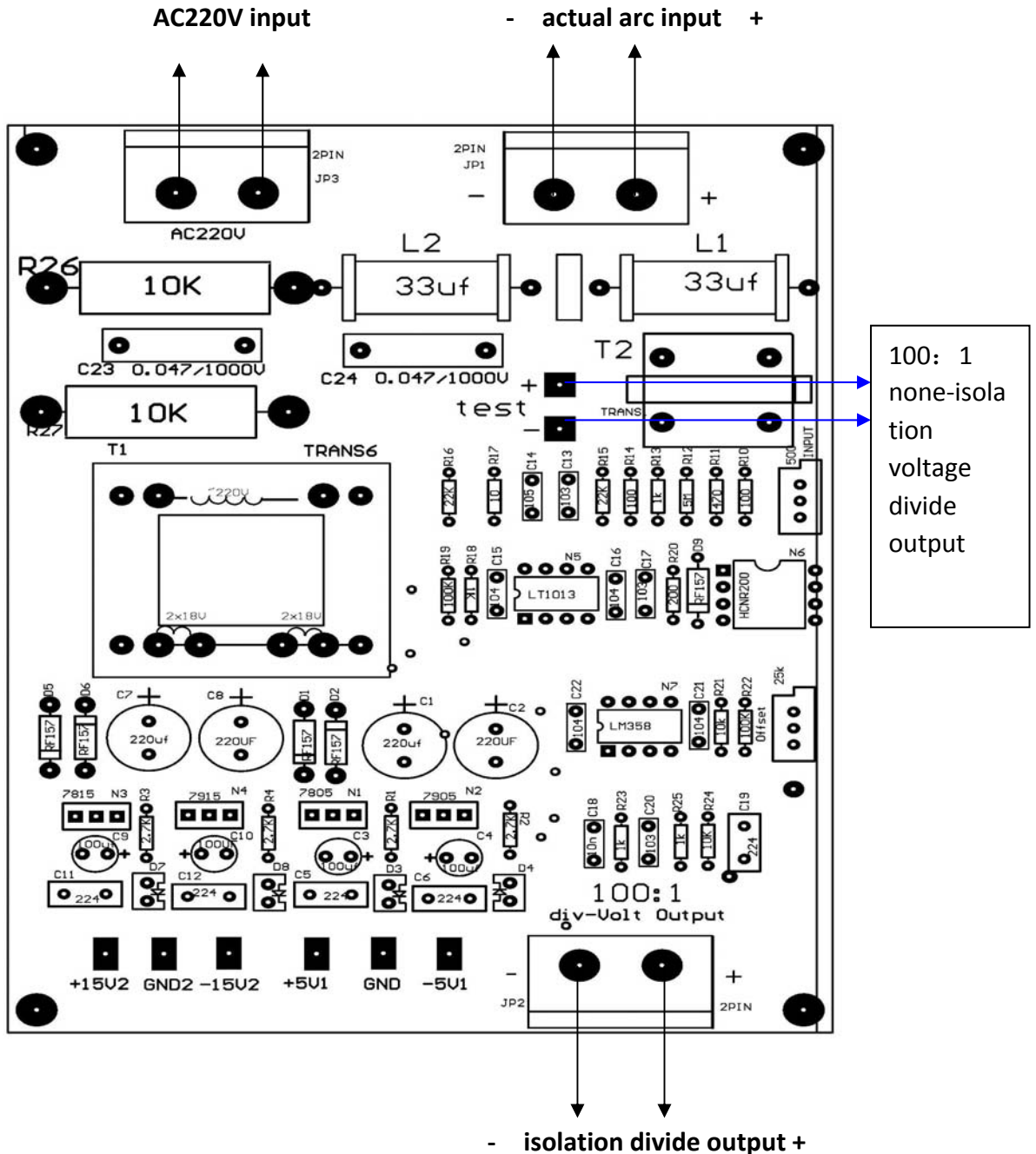

Figure 2-3

**Note: Non Isolation Voltage Divide is backup for Isolation Voltage Divide. On Non Isolation Voltage Divide, AC220V power can be unconnected; but it must be connected on Isolation Voltage Divide.**

## 2.3 IHS

### 2.3.1 Torch retaining cap IHS

The Torch Retaining Cap should be metal, so the metal can be electrically conducted with steel plate. XPTHC-100 has a piece of Isolated IHS plate that can be fixed in the THC directly, the connection showed as Figure 2-4 below:

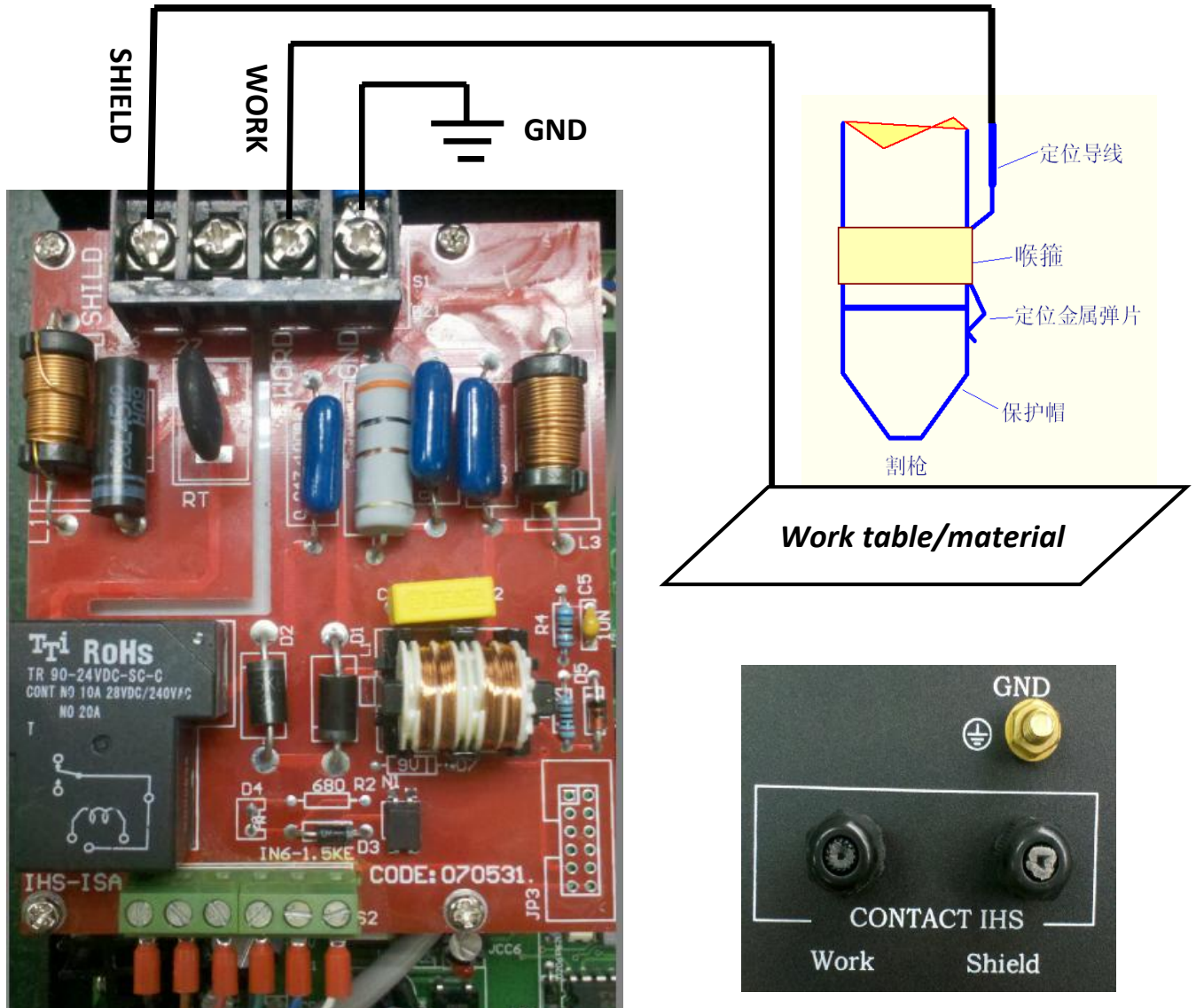

Figure 2-4

### Torch retaining cap IHS

THC receives arc start signal from CNC, lift torch down, when torch retaining cap touches steel, THC lift torch up to set IHS height. After IHS, THC control plasma to start arc.

---

**Note:**

- A、 The cable from SHIELD (marked as Shield on THC) to torch retaining cap.
- B、 The GND must be well grounded WORK must connected with ground, and the grounding cable must be >4mm<sup>2</sup>.
- C、 The cable connected to retaining cap must be High Voltage cable.

### 2.3.2 Proximity Switch IHS.

XPTH-100 III supports torch retaining cap IHS and proximity switch IHS both. We recommend proximity switch IHS, which can do IHS and anti-collision function job both, especially cutting rusty/painted steel.

Proximity Switch IHS uses 3-pin connector, named on THC "Switch IHS", Pin definition as follow,

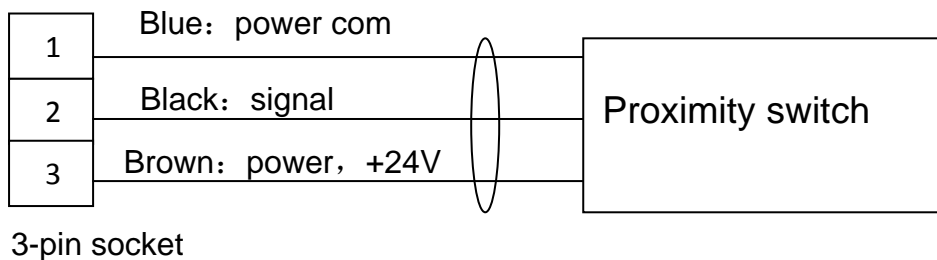

Figure 2-5

XPTH-100 uses 2 Proximity switches connected as above drawing, any one of them effective, THC can receive this signal, as figure 2-6 shows.

**Note:** In side THC, a 250mA Recoverable Fuse is installed at the powersupply of proximity switch, to avoid damage of power when proximity switch failed.

**Work Process:** Once THC received Arc Start signal from CNC, torch moves down, when it reaches workpiece, Proximity Switch leaves proximity position, THC receives this signal, lifts torch to the set height, (Proximity Switch recovers during lifting). After IHS, THC drives plasma Start Arc.

Proximity Switch IHS is suitable for all plasma IHS.

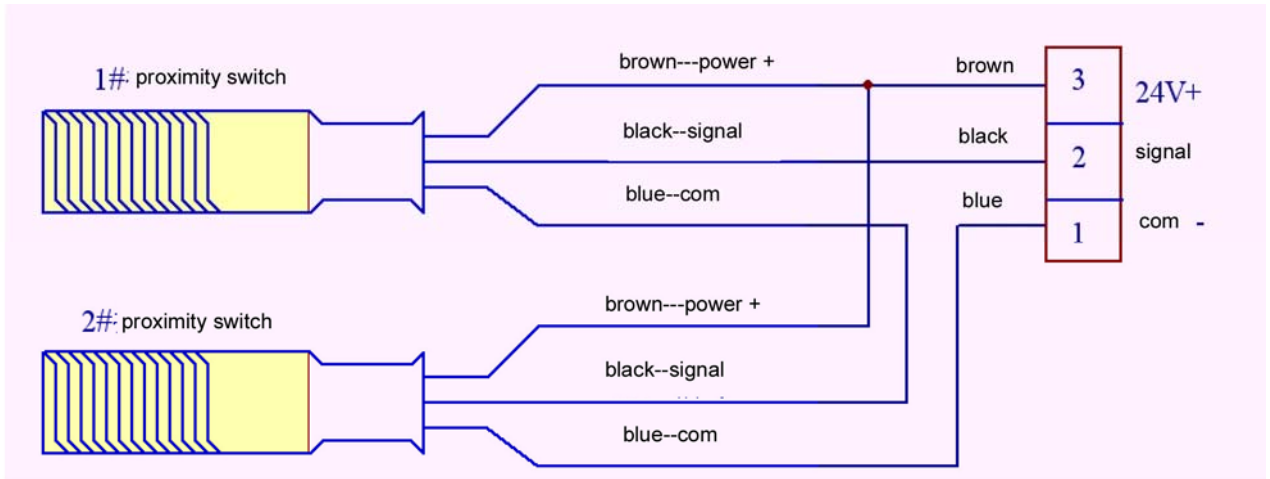

Figure 2-6

### 3 Wiring intro

Intro XPTHC-100III connectors' wiring details,

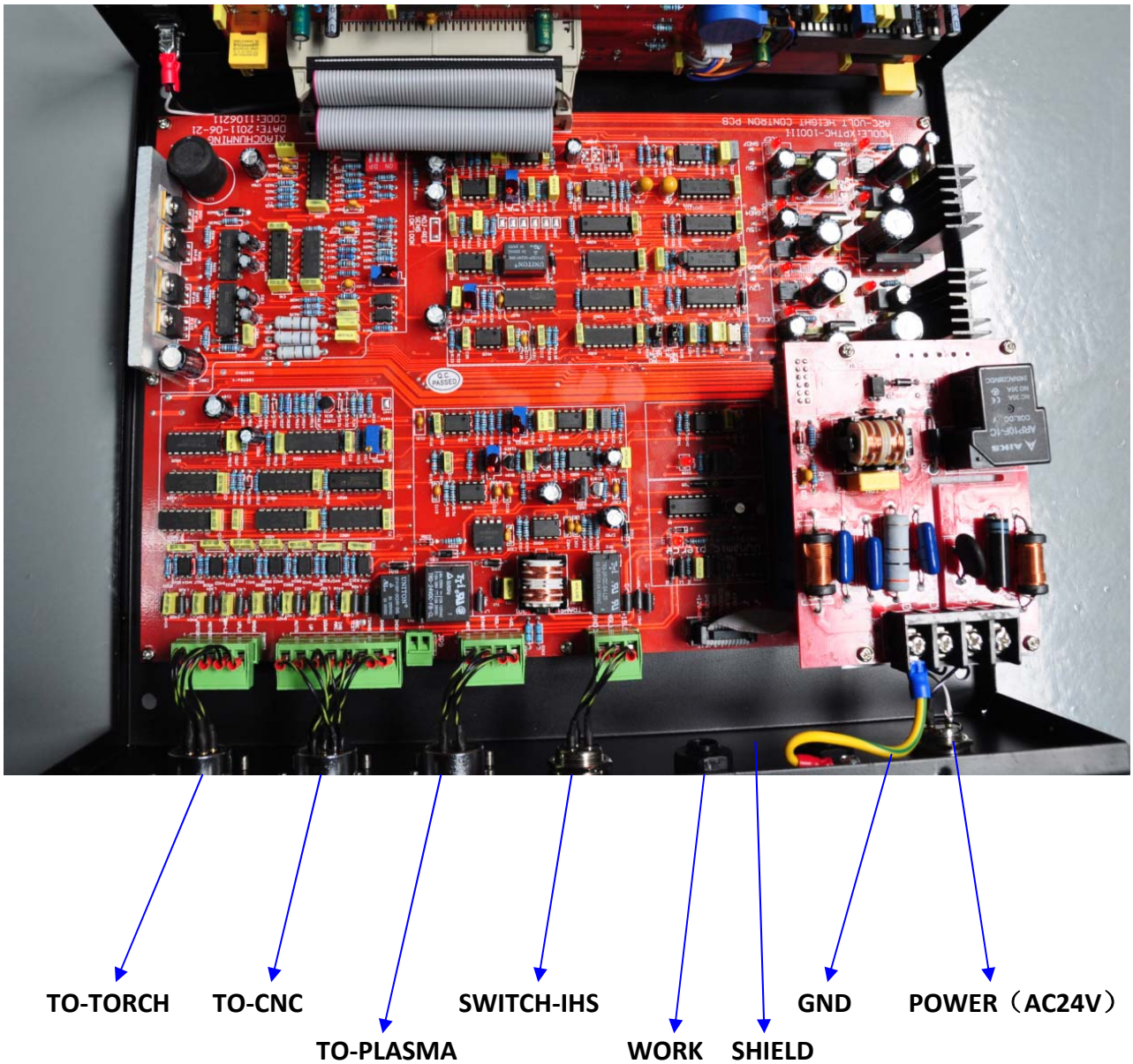

Figure 3-1

#### 3.1 Power

XPTHC-100 works under AC24V.  
Socket as right picture **POWER**,





### 3.2 Motor port

XPTHC-100 uses DC24Vmotor as drive output。  
Socket shows as right picture TO TORCH,



#### 3.2.1 TO TORCH

Pin(s)	Signal	Description
1 , 2	DC Motor Drive (Output)	DC motor drive output Drive DC24Vmotor directly Max 100W PWM
3	Down LIMIT (Input)	Down limit input Limit switch normally closed Short connect pin3 and 5 (optical ISOLATED)
4	Up LIMIT (Input)	Up limit input Limit switch normally closed Short connect pin4 and 5 (optical ISOLATED)
5	LIMIT COM	COM

Figure 3-1 TO MOTOR

#### 3.2.2 Drive current and set

The relationship between adjusting the SP2 current and the ON/OFF of Switch

Current	1-8	2-7	3-6	4-5
4A	OFF : PWM=9KHZ  ON : PWM=18KHZ	OFF	OFF	OFF
3A		OFF	OFF	ON
2A		OFF	ON	ON
1A		ON	ON	ON

Figure 3-2

### 3.3 To CNC

XPTHC-100 connect to CNC via a 10-pin socket  
Shows as right picture TO CNC,



**TO CNC** Figure 3-3 TO CNC

Pin(s)	Signal	Description
1	<b>AUTO</b>	Auto signal, low-level effective, Controlled by CNC's corner signal or THC enable signal, pin8 is control Com
2	<b>UP</b>	Up signal, low-level effective pin8 is control Com
3	<b>DOWN</b>	Down signal, low-level effective pin8 is control Com
4	<b>ARC ON with HIS</b>	Arc start with IHS, low-level effective pin8 is control Com
5	<b>EX ARC ON</b>	Arc start without IHS, low-level effective pin8 is control Com
6, 7	<b>Arc ok signal RELAY OUT (dry Contact)</b>	Connect to CNC's arc feedback signal input Relay output (dry contact)
8	<b>Control COM</b>	Isolation control COM
9	<b>Dynamic pierce port</b>	Switch signal or PWM control input
10		

TO CNC uses optical isolation, as follow picture shows,

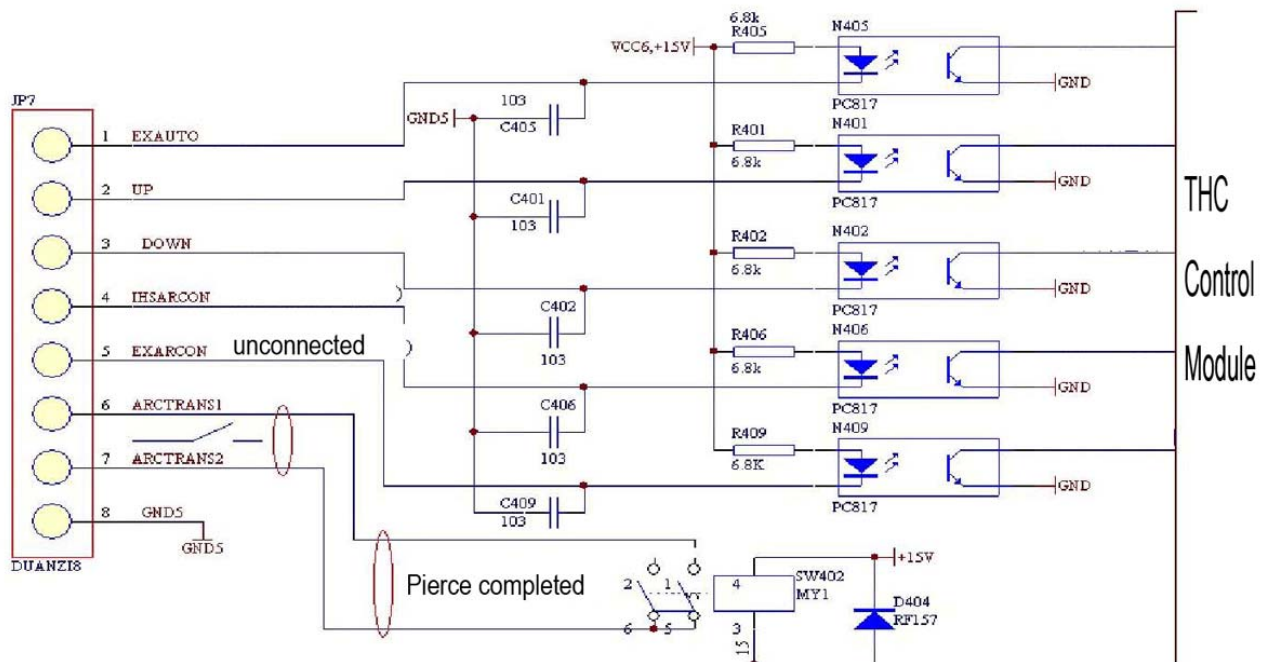

**Figure 3-4 TO CNC**

### 3.4 To plasma

XPTHC-100 connects to plasma via 4-pin socket,  
Marked as TO PLASMA,



#### TO PLASMA

Pin(s)	Signal	Description
1 , 2	Plasma start out	Plasma start signal output (Relay out, dry contact)
3	ARC + Input	Plasma input after voltage divide+
4	ARC - Input	Plasma input after voltage divide -

Figure 3-5

### 3.5 Proximity switch IHS port

XPTHC-100 proximity switch IHS port is 3-pin socket,  
Marked as SWITCH IHS,



#### SWITCH IHS

Pin(s)	Signal	Description
1	Switch Power -	proximity switch power negative port
2	Signal Input	Proximity switch signal
3	Switch Power +	proximity switch power positive port

Figure 3-6

## 4. THC wiring diagram.

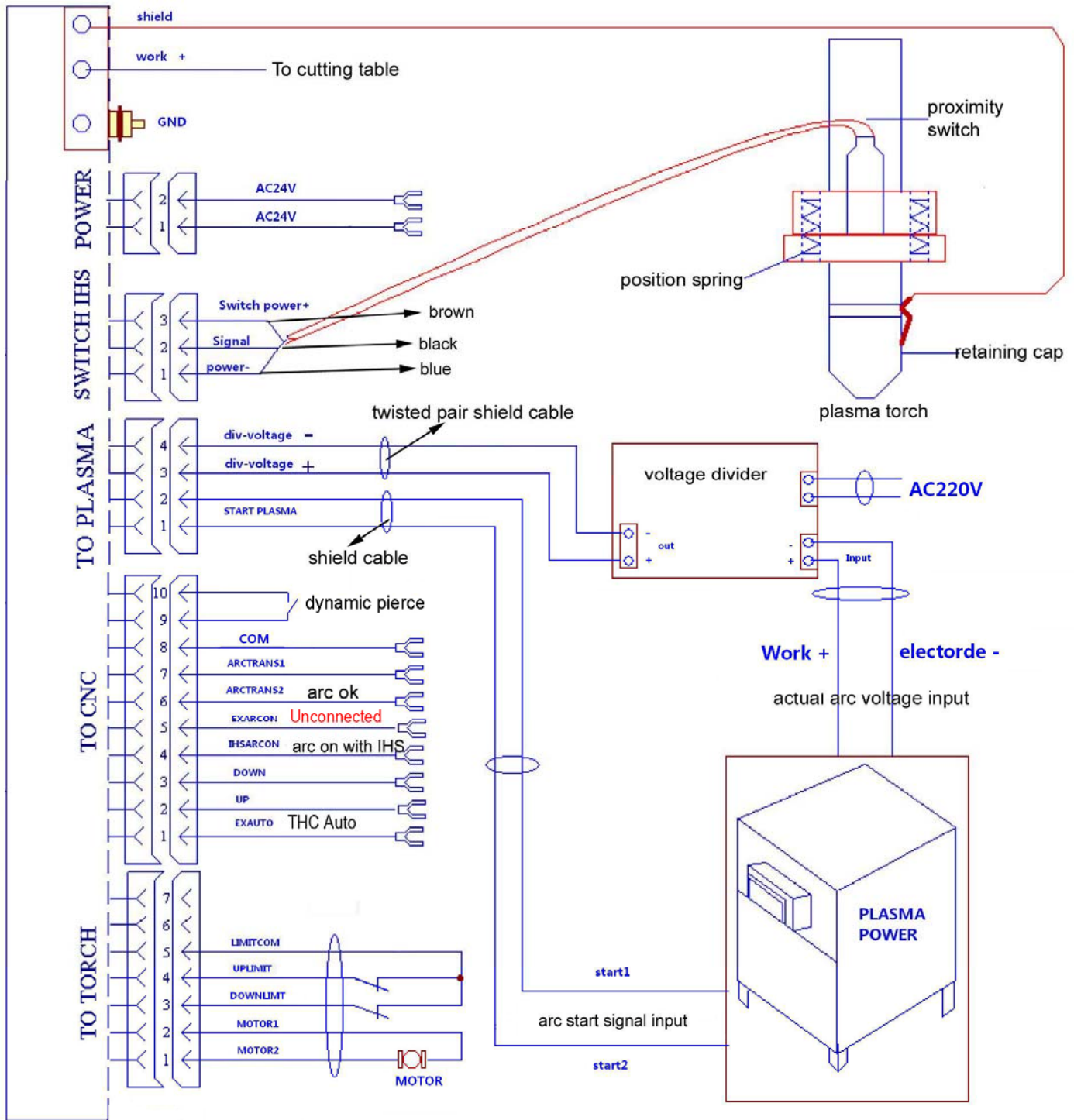

XPTHC-100 wiring diagram

## 5. Maintenance

### 5.1, Trouble shooting

Serial Number	Malfunction	Cause	Solution
1	No display, black screen	No + 5V voltage on the voltage meter	Check + 5V voltage VCC3
2	No rotation of motor or only one direction rotates.	1、 damage of drive IR2110	1、 replace IR2110
		2、 drive voltage + 15V, failure	Check drive voltage VCC4
		3、 protection of over-current	D606∞D609 (IRF640) is damaged or mechanical blocked
3	Once turn on, cutting torch keeps lifting。 (NPN)	1.Proximity switch is not installed well in the open-circuit condition	Install the Proximity switch perfectly
		2、 damage of Proximity switch	Replace Proximity switch (signal : 2mm, NPN)
4	Can not Start Arc automatically after the IHS	1、 damage of Proximity switch, no return signal	Replace Proximity switch
		2、 IHS time is too short, no return signal	Prolong the IHS switch
5	Instability of controlling arc voltage	1、 check the connection with earth 2、 check the water-proof 3、 over-sensitive	

6	CNC starts to work before the accomplishment of Arc Start	Setting time of SET-PIERE is too short	1、 increase SET-PIERE time 2、 adopt the arc feedback signal of Plasma itself
7	Plasma Arc Start before the IHS	using the EXARCON signal, the delay-time of CNC controlling is too short	Prolong the delay time of CNC IHS
8	Cutting torch can not start arc	1、 Confirm the working situation of Plasma power 2、 Check the height of IHS 3、 Check the cutting torch fittings	
9	Arc of Torch can not transfer to work piece	1、 Check the connection of working lead 2、 Check the cutting torch fittings	
10	Cutting torch move before piercing hole completed	Prolong the time of piercing hole in the CNC system	
11	CNC control starts, cutting torch heads down immediately	1、 Increase“ Set Arc Voltage” 2、 Prolong the automatic time in the CNC system 3、 Decrease the Over Voltage Protection No.(30V) 4、 Check the situation of Auto signal or Corner signal of CNC system	
12	Plasma arc out after the arc transferring and piercing hole	1、 Delay-time is too long	
13	During IHS, the cutting torch touches the steel plate but no movement upwards.	1、 Time of HIS is too short 2、 Induced lead connect with protection badly	

14	Cutting torch keeps heading down after touching work piece, and no Arc Start	1、 Weak contact between detecting cable and retaining cap. 2、 Proximity switch is damaged 3、 “ WORK” in THC is bad connection with earth
15	Cutting torch move unsteadily on Auto mode	1、 THC is over sensitive , turn RP501 anti-clockwise 2、 THC damaged
16	THC is too slow on tracking, on auto-state	1、 THC is low sensitive , turn RP501 clockwise
17	Arc off during the cutting, and Arc Voltage Enable signal keeps sending out, machine still runs	problem : THC can not stop immediately since it works with arc voltage signal. solution : adopt the Arc OK signal of Plasma itself

**Figure 5-1**

### 5.3、 Some advice

1. For Better control accuracy and stable work, we suggest customer to use XPTHC-100III with our Anti-collision fixture and Ballscrew Lifter (Figure 5-2). In practice, when the contact between Retaining Cap and workpiece is weak (especially the workpiece is Rusty or painted steel plate,) Proximity Switch IHS is a necessary part for Torch height control.. If Torch Retaining Cap IHS and Proximity Switch IHS both installed, both will be active during cutting.
2. When it is using proximity switch function, we suggest try some more proximity switches, and all switched by outside circuit.
- 3. The cable connecting Voltage Divider and THC must be SHIELD cable, and shall be separated away from Arc Start cable.**

---

4. When it is HF plasma, please use shield cable on TO Torch connection port (connect motor). One side of shield connects to socket, another side connect to torch. And it should be away from torch cutting cable, to avoid lead in plasma high voltage into THC control circuit.



Figure 5-2



**CORPORATE & MANUFACTURING**

**TOMATECH(SHENZHEN)AUTOMATION CO.,LIMITED**

#1803 Shangbao Building, Xinwen Road,  
Futian District, Shenzhen- China

**Dealer : INDIA**

**SV TECHNOLOGIES**

No:32, Block - !  
Badal Residency Tower,  
Periyar Street, Anna Nagar  
Hasthinapuram, Chennai-600064  
Mob/What's app: +91 9940121003  
Web.: www.svtechs.com  
Ph: +91 44 48515300  
Email: svtechnologies1222@gmail.com

